

ETA 955.1x2 / 4x2

COMMUNICATION
TECHNIQUE

TECHNISCHE
MITTEILUNG

TECHNICAL
COMMUNICATION

10½" ou
oder
or 11½"

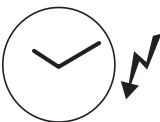
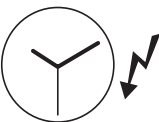
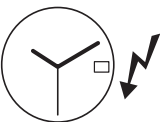
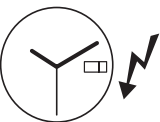
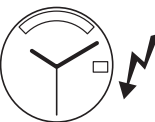
					
	LOGLIFE	E.O.L.	E.O.L.	E.O.L.	E.O.L.
Hauteur mouvement Werkhöhe Movement height	2,50 mm	2,50 mm	2,50 mm	3,00 mm	3,00 mm
Hauteur sur pile Höhe auf Batterie Height on battery	2,62 mm	2,62 mm	2,62 mm	3,12 mm	3,12 mm
10½" Ø 23,30 mm	955.432	955.402	955.412	955.422	
11½" Ø 25,60 mm		955.102	955.112	955.122	955.132

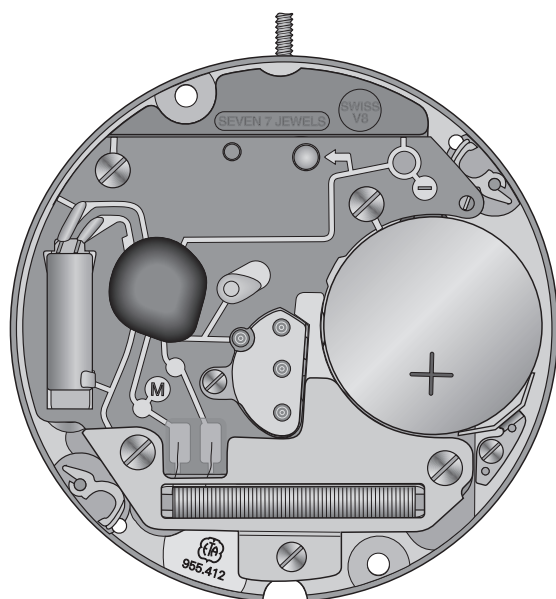

Interchangeabilité – Auswechselbarkeit – Interchangeability

No Nr No	No Nr CS No	LISTE DES FOURNITURES	BESTANDTEILE	LIST OF MATERIALS	Cal. – Kal. – Cal.							
					955.102	955.112	955.122	955.132	955.402	955.412	955.422	955.432
100	10.020.07	Platine, empierrée	Werkplatte, mit Steinen	Main plate, jewelled	955.102	955.112	955.122	955.132	955.402	955.412	955.422	955.432
110	10.048.07	Pont de rouage, empierré	Räderwerkbrücke, mit Steinen	Train wheel bridge, jewelled	956.112	956.112	956.112	956.112	956.112	956.112	956.112	956.112
144	10.300.00	Fixateur de cadran	Zifferblatthalter	Dial fastener	2850	2850	2850	2850	2850	2850	2850	2850
145	10.106.00	Support de cadran	Träger für Zifferblatt	Dial support	---	---	955.121	955.121	---	---	955.421	---
147	10.280.00	Porte-marque	Platte für Markenzeichen	Mark support	950.001	950.001	950.001	950.001	950.001	950.001	950.001	950.001
161	80.400.00	Tube de centre	Zentrumlagerrohr	Centre tube	956.101	956.101	956.101	956.101	956.101	956.101	956.101	956.101
203	30.012.00	Roue intermédiaire	Zwischenrad	Intermediate wheel	956.101	956.101	956.101	956.101	956.101	956.101	956.101	956.101
210	30.025.00	Roue moyenne	Kleinbodenrad	Third wheel	956.101	956.101	956.101	956.101	956.101	956.101	956.101	956.101
227	30.027.00	Roue de seconde	Sekundenrad	Second wheel	956.101	956.101	956.101	956.101	956.101	956.101	956.101	---
227/3	30.027.18	Roue de seconde, sans seconde au centre	Sekundenrad, ohne Zentralsekunde	Second wheel, without sweep second	---	---	---	---	---	---	---	956.031
242	31.083.00	Chaussée avec entraîneur	Minutenrohr mit Mitnehmer	Cannon pinion with driver	956.101	956.101	956.101	956.101	956.101	956.101	956.101	---
242/1	31.083.18	Chaussée avec entraîneur, sans seconde au centre	Minutenrohr mit Mitnehmer, ohne Zentralsekunde	Cannon pinion with driver, without sweep second	---	---	---	---	---	---	---	956.031
255	31.046.00	Roue des heures	Stundenrad	Hour wheel	---	---	956.121	956.121	---	---	956.121	---
255/1	31.046.06	Roue des heures, montée	Stundenrad, montiert	Hour wheel, assembled	956.101	956.101	---	---	956.101	956.101	---	956.101
260	31.041.00	Roue de minuterie	Wechselrad	Minute wheel	956.101	956.101	956.101	956.101	956.101	956.101	956.101	956.101
405	51.020.21	Tige de mise à l'heure, Ø filetage 0,90 mm	Stellwelle, Gewindedurchmesser 0,90 mm	Handsetting stem, thread diameter 0.90 mm	956.101	956.101	956.101	956.101	956.101	956.101	956.101	956.101
405/4	51.021.00	Tige de mise à l'heure, partie mouvement	Stellwelle, Werkteil	Handsetting stem, movement part	955.101	955.101	955.101	955.101	955.401	955.401	955.401	955.401
407	31.121.00	Pignon coulant	Kupplungstrieb	Sliding pinion	956.101	956.101	956.101	956.101	956.101	956.101	956.101	956.101
435	51.050.00	Bascule de pignon coulant	Kupplungstriebhebel	Yoke	956.112	956.112	956.112	956.112	956.112	956.112	956.112	956.112
443/1	51.080.06	Tirette, montée	Winkelhebel, montiert	Setting lever, assembled	956.101	956.101	956.101	956.101	956.101	956.101	956.101	956.101
445	51.090.00	Sautoir de tirette	Winkelhebelraste	Setting lever jumper	956.101	956.111	956.111	956.111	956.101	956.111	956.111	956.101
450	31.100.00	Renvoi	Zeigerstellrad	Setting wheel	956.101	956.101	956.101	956.101	956.101	956.101	956.101	956.101
462	10.062.00	Pont de rouage de minuterie	Wechselradbrücke	Minute train bridge	956.101	956.101	956.121	956.121	956.101	956.101	956.121	956.101
549	81.185.00	Clavette de tirette	Klemmscheibe für Winkelhebel	Setting lever spring-clip	956.101	956.101	956.101	956.101	956.101	956.101	956.101	956.101
560	56.071.00	Levier d'arrêt et interrupteur	Stoppehebel und Unterbrecher	Stop lever and switch	956.101	956.101	956.101	956.101	956.101	956.101	956.101	956.101
2543	33.011.00	Roue intermédiaire de quantième	Datum-Zwischenrad	Intermediate date wheel	---	956.111	956.111	956.111	---	956.111	956.111	---
2555	33.028.00	Roue entraîneuse du calendrier	Kalender-Mitnehmerrad	Calendar driving wheel	---	---	956.121	956.121	---	---	956.121	---
2556	33.020.00	Roue entraîneuse de l'indicateur de quantième	Datumanzeiger-Mitnehmerrad	Date indicator driving wheel	---	956.111	---	---	---	956.111	---	---
2557/1	91.440.22	Indicateur de quantième, ouverture de guichet à 3h	Datumanzeiger, für Fenster bei 3 Uhr	Date indicator, for opening at 3 o'clock	---	955.111	955.121	955.132	---	955.411	955.421	---
2561/1	91.441.42	Indicateur du jour, pour ouverture rectangulaire horizontale à 3 h	Tagesanzeiger, für rechteckiges horizontales Fenster bei 3 Uhr	Day indicator, for horizontal rectangular opening at 3 o'clock	---	---	955.121	---	---	---	955.421	---
2561/1	91.441.21	Indicateur du jour, pour ouverture en arc de cercle à 12 h	Tagesanzeiger, für bogenförmiges Fenster bei 12 Uhr	Day indicator, for circular arc opening at 12 o'clock	---	---	---	955.132	---	---	---	---
2566	53.200.00	Correcteur de quantième	Datumkorrektor	Date corrector	---	956.111	---	---	---	956.111	---	---
2567	53.201.00	Correcteur des jours	Tageskorrektor	Day corrector	---	---	956.121	956.121	---	---	956.121	---
2569	53.204.00	Correcteur double	Doppelkorrektor	Double corrector	---	---	956.121	956.121	---	---	956.121	---

Interchangeabilité – Auswechselbarkeit – Interchangeability

No Nr No	No Nr CS No	LISTE DES FOURNITURES	BESTANDTEILE	LIST OF MATERIALS	Cal. – Kal. – Cal.								
					955.102	955.112	955.122	955.132	955.402	955.412	955.422	955.432	
	2570	53.026.00	Commande du correcteur double	Schalthebel für Doppelkorrektor	Double corrector operating lever	956.101	956.101	956.101	956.101	956.101	956.101	956.101	956.101
	2573	63.032.00	Ressort du sautoir des jours	Feder für Tagesraste	Day jumper spring	---	---	956.121	956.121	---	---	956.121	---
	2576	53.080.00	Sautoir de quantième	Datumraste	Date jumper	---	955.112	955.112	955.112	---	955.112	955.112	---
	2577	53.081.00	Sautoir des jours	Tagesraste	Day jumper	---	---	956.121	956.121	---	---	956.121	---
	2595	13.111.00	Plaque de maintien du sautoir de quantième	Halteplatte für Datumraste	Date jumper maintaining plate	---	956.101	956.101	956.101	---	956.101	956.101	---
	2780	83.171.00	Clavette de l'indicateur du jour	Klemmscheibe für Tagesanzeiger	Day indicator spring-clip	---	---	2648	2648	---	---	2648	---
	4000	10.513.00	Module électronique	Elektronik-Baugruppe	Electronic module	955.112	955.112	955.112	955.112	955.112	955.112	955.112	955.432
	4021	20.582.00	Stator	Stator	Stator	955.101	955.101	955.101	955.101	955.101	955.101	955.101	955.101
	4022	80.102.00	Entretoise du module électronique	Zwischenstück für Elektronik-Baugruppe	Electronic module distance piece	955.101	955.101	955.101	955.101	955.101	955.101	955.101	955.101
	4038	20.584.00	Ecran magnétique supérieur	Oberer Magnetschirm	Upper magnetic screen	955.112	955.112	955.112	955.112	955.112	955.112	955.112	955.112
	4046	20.651.00	Isolateur de pile	Isolation für Batterie	Battery insulator	955.101	955.101	955.101	955.101	955.101	955.101	955.101	955.101
	4211	20.580.00	Rotor	Rotor	Rotor	956.101	956.101	956.101	956.101	956.101	956.101	956.101	956.101
	4233	80.246.00	Rivet de stator	Niete für Stator	Rivet for stator	956.101	956.101	956.101	956.101	956.101	956.101	956.101	956.101
	4407	20.764.00	Bride de masse	Massen-Bügel	Earth connector	955.101	955.101	955.101	955.101	955.101	955.101	955.101	955.101
	4412	10.601.00	Ressort de limitation de pile	Begrenzungsfeder für Batterie	Battery limiting spring	955.101	955.101	955.101	955.101	955.101	955.101	955.101	955.101
	4929	20.570.00	Pile, H. 2,05 mm	Batterie, H. 2,05 mm	Battery, H. 2.05 mm	955.101	955.101	955.101	955.101	955.101	955.101	955.101	955.101
	4929/1	20.570.18	Pile spéciale, H. 2,70 m	Batterie, Spezial-Ausführung, H. 2,70 mm	Battery, special, H. 2.70 mm	955.101	955.101	955.101	955.101	955.101	955.101	955.101	955.101
	5101	10.020.01	Vis de fixation	Schraube für Werkbefestigung	Screw for case	956.401	956.401	956.401	956.401	956.401	956.401	956.401	956.401
	5102	10.020.02	Vis de fixation, spéciale	Schraube für Werkbefestigung, Spezial-Ausführung	Screw for case, special	956.401	956.401	956.401	956.401	956.401	956.401	956.401	956.401
	5110	10.048.01	Vis de pont de rouage	Schraube für Räderwerkbrücke	Screw for train wheel bridge	956.101	956.101	956.101	956.101	956.101	956.101	956.101	956.101
1)	5462	10.062.01	Vis de pont de rouage de minuterie	Schraube für Wechselradbrücke	Screw for minute train bridge	956.101	956.101	956.101	956.101	956.101	956.101	956.101	956.101
	52567	53.201.01	Vis de correcteur des jours	Schraube für Tageskorrektor	Screw for day corrector	---	---	956.121	956.121	---	---	956.121	---
1)	52573	63.032.01	Vis de ressort du sautoir des jours	Schraube für Tagesrastefeder	Screw for day jumper spring	---	---	956.121	956.121	---	---	956.121	---
1)	52595	13.111.01	Vis de plaque de maintien du sautoir de quantième	Schraube für Halteplatte für Datumraste	Screw for date jumper maintaining plate	---	956.101	956.101	956.101	---	956.101	956.101	---
	54000	10.513.01	Vis de module électronique, longue	Schraube für Elektronik-Baugruppe, lang	Screw for electronic module, long	955.112	955.112	955.112	955.112	955.112	955.112	955.112	955.112
	54000'	10.513.02	Vis de module électronique, courte	Schraube für Elektronik-Baugruppe, kurz	Screw for electronic module, short	955.112	955.112	955.112	955.112	955.112	955.112	955.112	955.112
2)	54038	20.584.01	Vis d'écran magnétique supérieur	Schraube für oberen Magnetschirm	Screw for upper magnetic screen	955.112	955.112	955.112	955.112	955.112	955.112	955.112	955.112
2)	54407	20.764.01	Vis de bride de masse	Schraube für Massen-Bügel	Screw for earth connector	955.112	955.112	955.112	955.112	955.112	955.112	955.112	955.112
			* Voir plan de vis en page 14 Siehe Schraubenplan auf Seite 14 See screws plan on page 14										

955.102 / 112 / 122 / 132 / 402 / 412 / 422 / 432

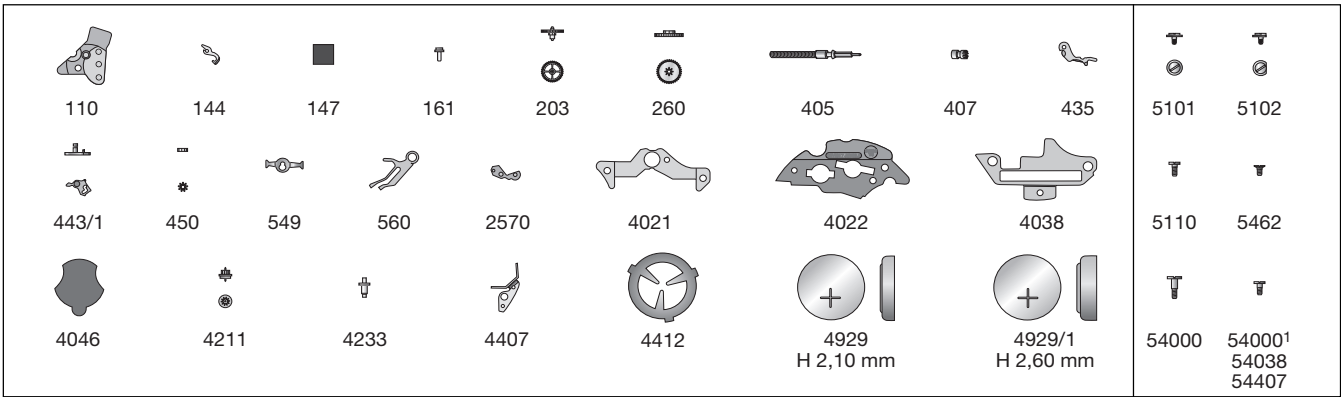

955.102 / 112 / 122 / 132 / 402 / 412 / 422

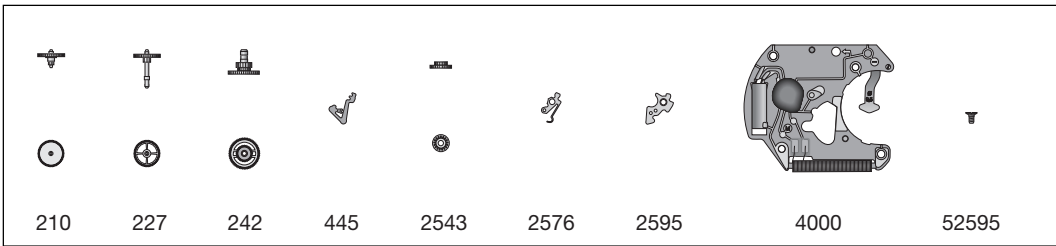

955.122 955.132

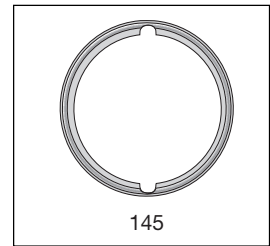

955.122 / 132 / 422

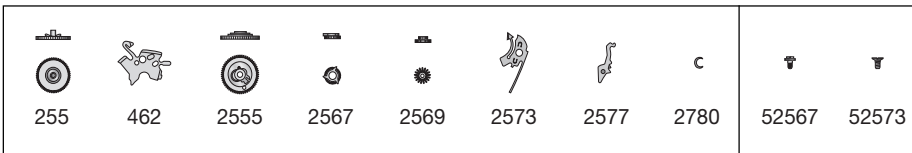

955.102 / 112
955.122 955.132

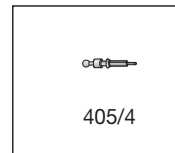

955.402 / 412
955.422 955.432

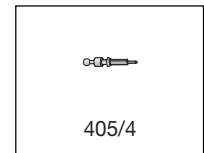

955.102 / 112

955.402 / 412 / 432

955.112 / 412

955.102 / 112

955.112

955.402 / 412

955.412

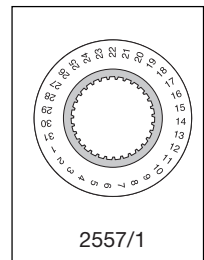
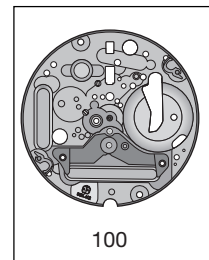
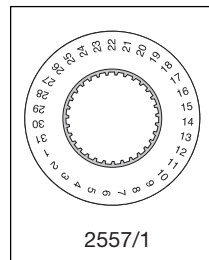
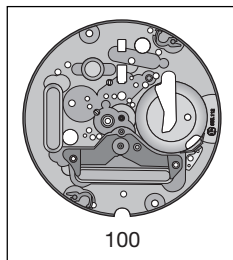
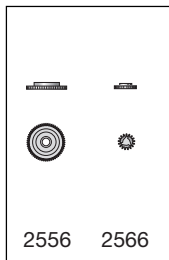
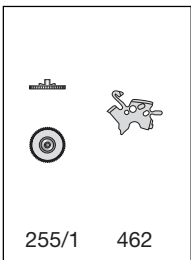

955.122

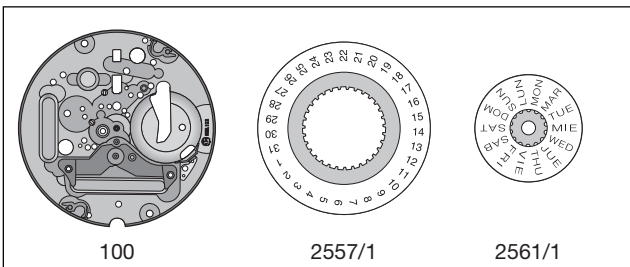

955.132

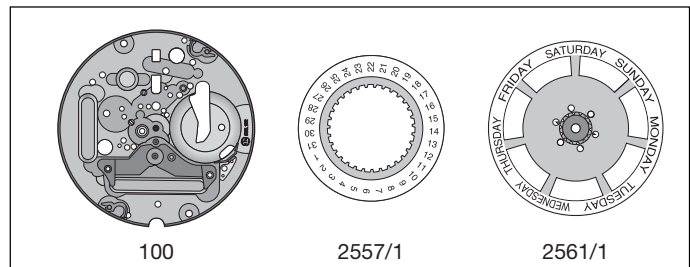

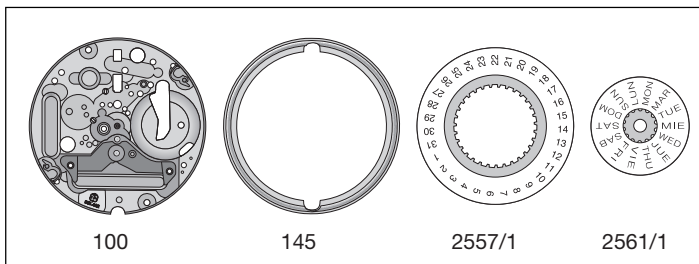

955.422

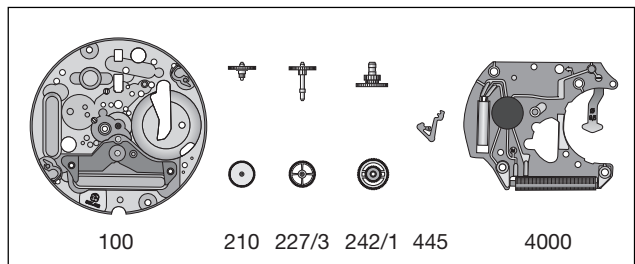

955.432



Lubrification – Schmierung – Lubrication

	Huile fine Dünnflüssiges Öl Fine oil	Moebius 9014 ou / oder / or Moebius 9034
	Très faible lubrification Sehr kleine Menge Very little lubrication	Moebius 9014 ou / oder / or Moebius 9034
	Huile épaisse à viscosité élevée ou graisse Dickflüssiges druckfestes Öl oder Fett Thick, pressure-resistant oil or grease	Moebius D5 ou / oder / or HP 1300

Montage du mouvement de base

(Liste des fournitures par ordre d'assemblage)

Zusammenstellen des Basiswerkes

(Bestandteilliste in Montager Reihenfolge)

Assembling of the basic movement

(Parts listed in order of assembly)

100	210
161	4211
407	227
405	203
2570	560
445	110
443/1	5110 (1x)
549	

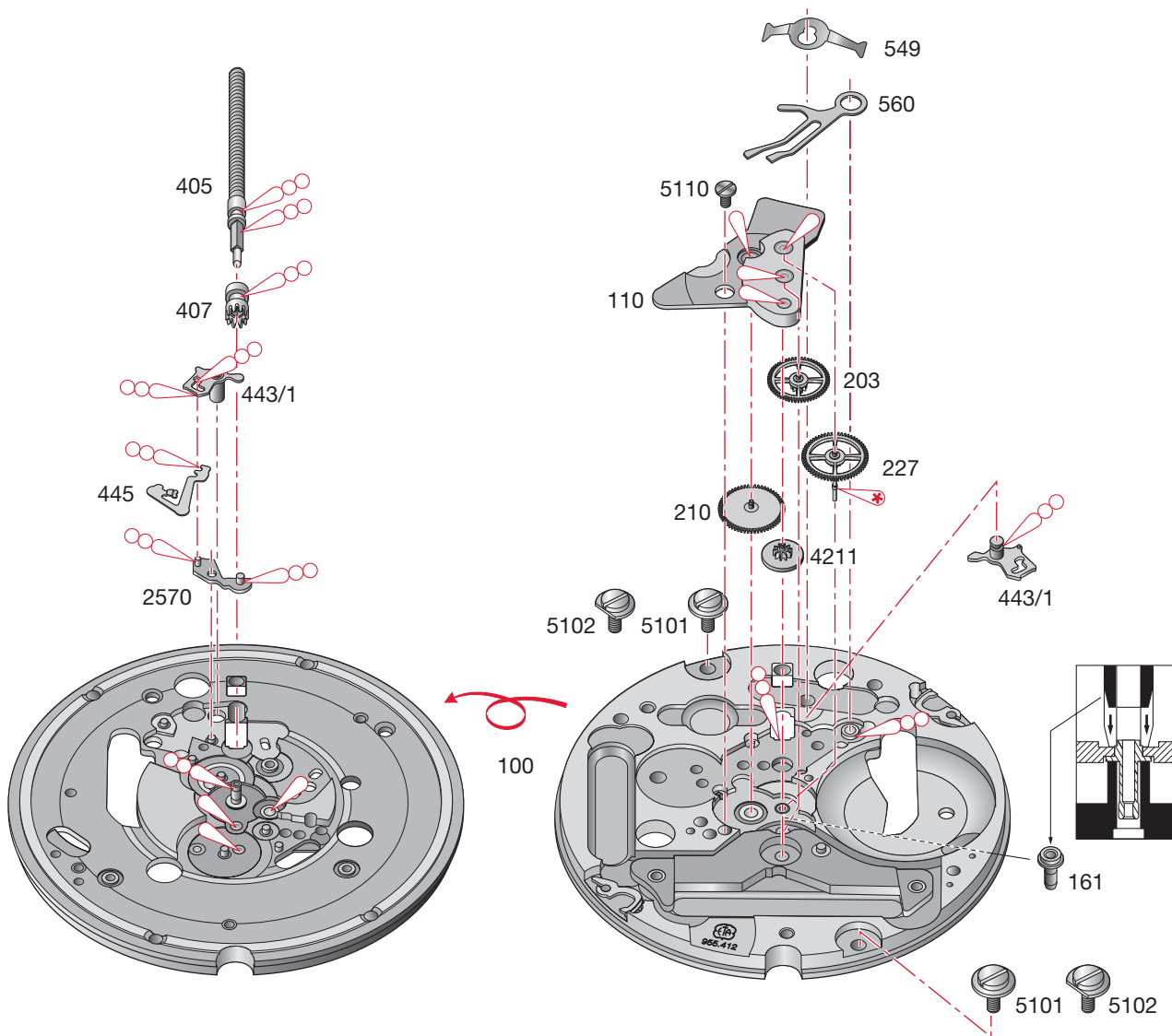

**Montage du mécanisme de mise à l'heure
et du mécanisme de calendrier**

(Liste des fournitures par ordre d'assemblage)

**Zusammenstellen des Zeigerwerkmechanismus
und des Kalendermechanismus**



(Bestandteilliste in Montager Reihenfolge)

**Assembling of the handsetting
and the calendar mechanism**

(Parts listed in order of assembly)

242	2557/1
260	2556
450	2543
2566	2576
435	2595
462	52595 (1x)
5462 (1x)	255/1

Lubrification – Schmierung – Lubrication

	Huile épaisse à viscosité élevée ou graisse Dickflüssiges druckfestes Öl oder Fett Thick, pressure-resistant oil or grease	Moebius D5 ou / oder / or HP 1300
	Très faible lubrification Sehr kleine Menge Very little lubrication	Moebius D5 ou / oder / or HP 1300
	Graisse Fett Grease	Moebius 9501 ou / oder / or Jismaa 124

955.112 : 11½"

955.412 : 10½"

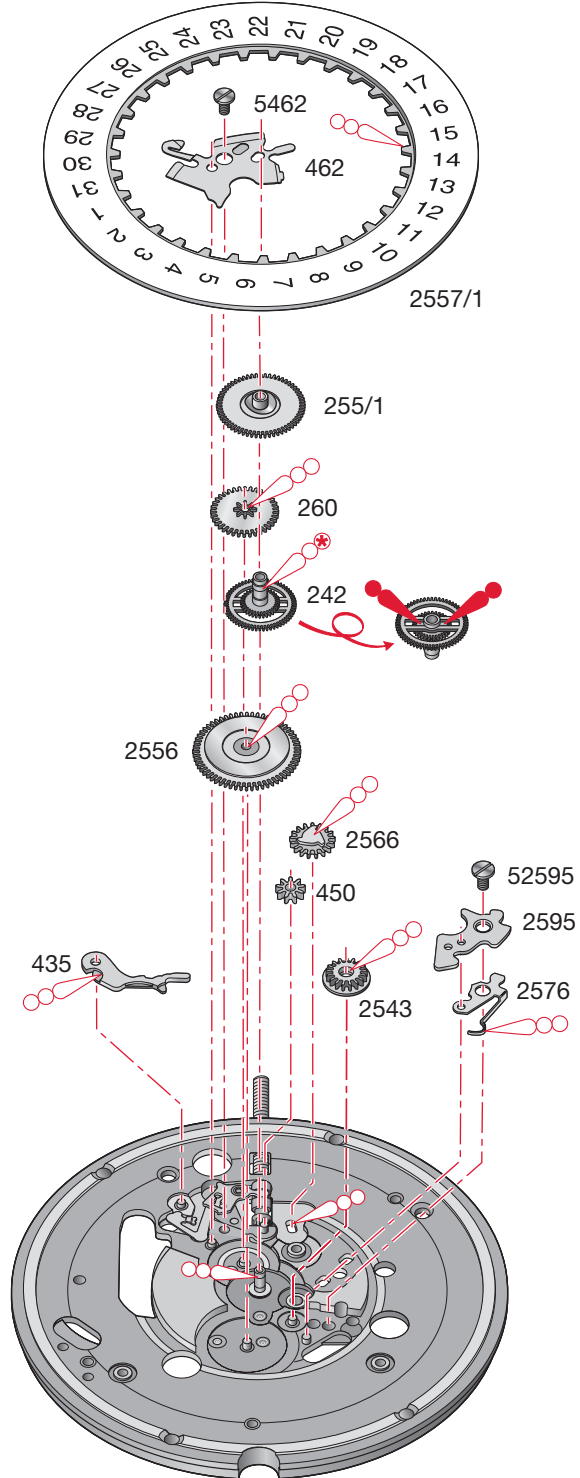

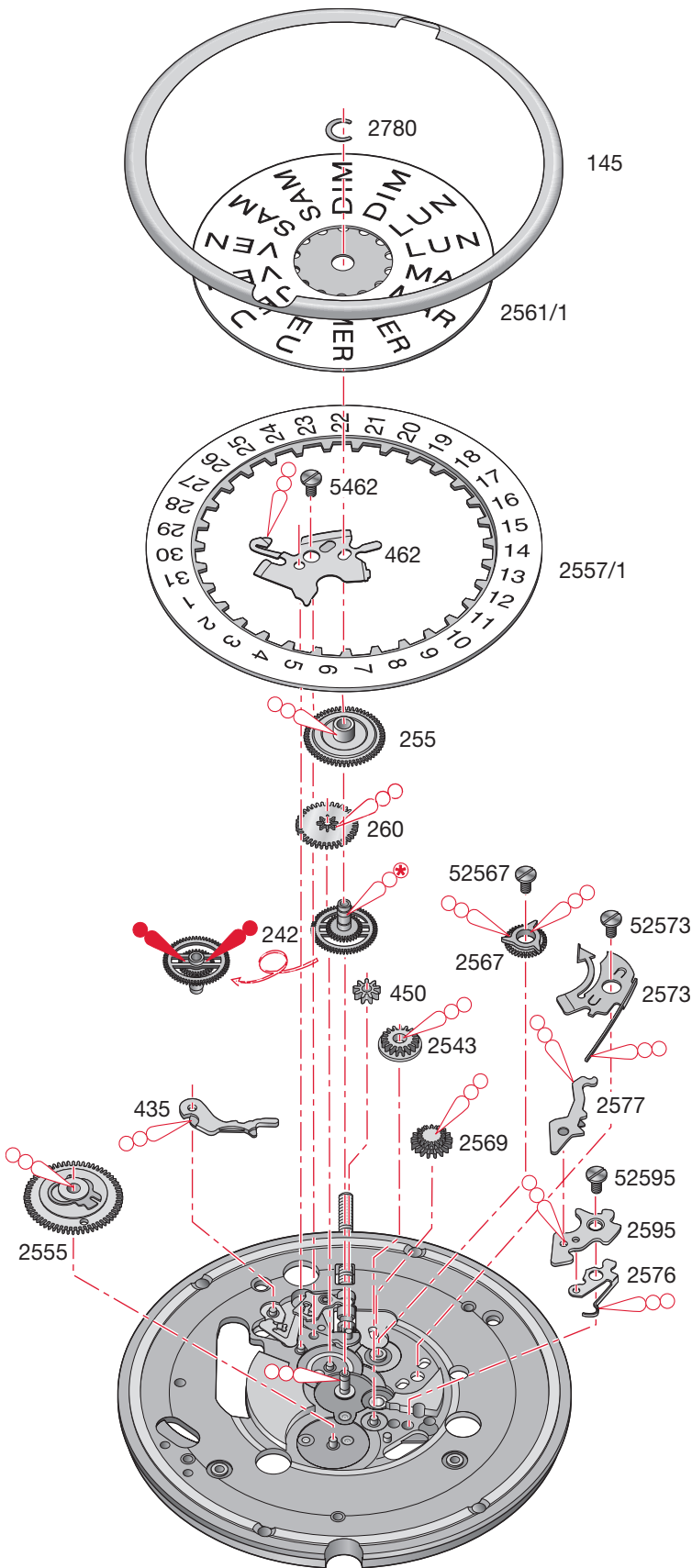

Montage du mécanisme de mise à l'heure et du mécanisme de calendrier

(Liste des fournitures par ordre d'assemblage)

Zusammenstellen des Zeigerwerkmechanismus und des Kalendermechanismus

(Bestandteilliste in Montager Reihenfolge)

Assembling of the handsetting and the calendar mechanism

(Parts listed in order of assembly)

242	2543
260	2576
450	2595
2569	52595 (1x)
2567	255
52567 (1x)	2573
435	52573 (1x)
462	2577
5462 (1x)	2561/1
2557/1	2780
2555	145

955.122 : 11½'''

955.422 : 10½'''

Lubrification – Schmierung – Lubrication

Huile épaisse à viscosité élevée ou graisse
 Dickflüssiges druckfestes Öl oder Fett
 Thick, pressure-resistant oil or grease



Moebius D5
 ou / oder / or
HP 1300

Très faible lubrification
 Sehr kleine Menge
 Very little lubrication



Moebius D5
 ou / oder / or
HP 1300

Graisse
 Fett
 Grease



Moebius 9501
 ou / oder / or
Jismaa 124

**Montage du mouvement de base
et de la partie électronique**

(Liste des fournitures par ordre d'assemblage)

**Zusammenstellen des Basiswerkes
und des elektronischen Teils**

(Bestandteilliste in Montager Reihenfolge)

**Assembling of the basic movement
and the electronic part**

(Parts listed in order of assembly)

4407	54000 (3x)
54407 (1x)	54000 ¹ (1x)
4022	4038
4046	54038 (1x)
4000	4929

4412



Nécessaire, si la sûreté entre le mouvement et le fond de la boîte est trop élevée.

Nur nötig, wenn der Abstand Werk-Gehäuseboden zu gross ist.

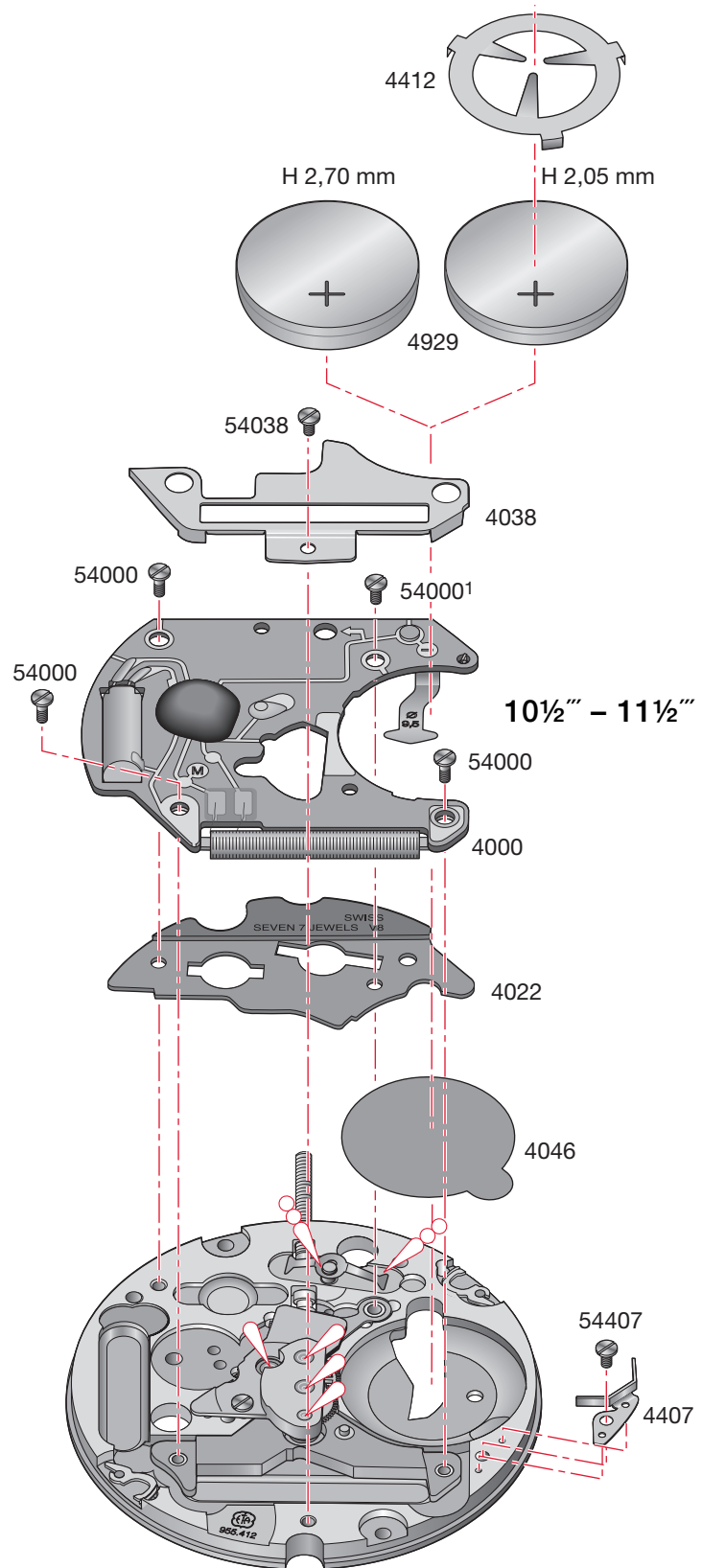
To be fitted when the clearance between the movement and the case back is too great.



Lubrification – Schmierung – Lubrication

	Huile fine Dünnflüssiges Öl Fine oil	Moebius 9014 ou / oder / or Moebius 9034
	Huile épaisse à viscosité élevée ou graisse Dickflüssiges druckfestes Öl oder Fett Thick, pressure-resistant oil or grease	Moebius D5 ou / oder / or HP 1300

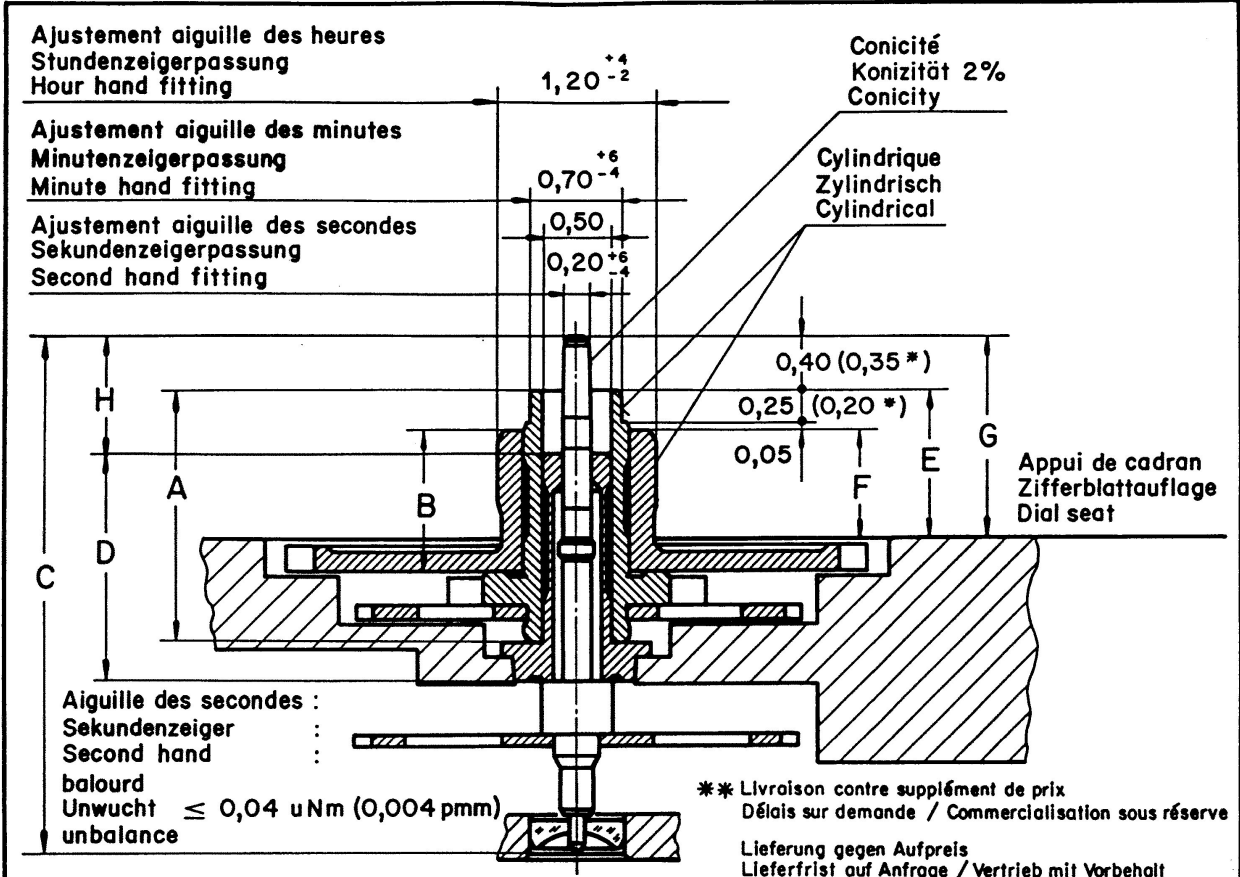

masse
Masse ≤ 10 mg
mass

Aiguille des minutes : balourd
Minutenzeiger : Unwucht ≤ 3,0 μNm
Minute hand : unbalance (0,3 pmm)

** Livraison contre supplément de prix
Délais sur demande / Commercialisation sous réserve

Lieferung gegen Aufpreis
Lieferfrist auf Anfrage / Vertrieb mit Vorbehalt

Delivery with surcharge / Delivery schedule on demand
Market launch with specific conditions

* Pour aiguillage O (réduit) cadran ép. 0,30
Für Zeigerwerkhöhe O (niedrig) Zifferblattstärke 0,30
For hand fitting height O (reduced) dial thickness 0,30

Aiguillage Zeigerwerk- höhe Hand fitting height	Longueur/Länge/Length				Dépassement Höhe über Zifferblattauflage Height over dial seat			H
	A	B	C	D	E	F	G	
	Chaussée Minutenrohr Cannon pinion	Roue des heures Stundenrad Hour wheel	Pignon des sec. Sekundentrieb Second wheel pinion	Tube de centre Zentrumrohr Centre tube	Chaussée Minutenrohr Cannon pinion	Roue des heures Stundenrad Hour wheel	Pignon des sec. Sekundentrieb Second wheel pinion	
réduit * niedrig reduced	1,66	0,89	3,63	1,70	0,90	0,65	1,25	0,60
1 normal	1,88	1,06	3,88	1,70	1,10	0,80	1,50	0,85
3 **	2,38	1,56	4,38	1,70	1,60	1,30	2,00	1,35
4 **	2,63	1,81	4,63	1,70	1,85	1,55	2,25	1,60
5 **	2,88	2,06	4,88	1,70	2,10	1,80	2,50	1,85

Aiguillages
Zeigerwerkhöhen
Hand fitting heights

Cal. 955. 102/112/402/412/612
956. 102/112/402/412/612

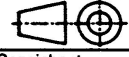
Änderungen: Modifications:	990312658 hm	 ETA SA Fabriques d'Ebauches CH-2540 Grenchen	Masse in mm Dim. en mm Dim. in mm	Tol. in 1/1000 mm Tol. en 1/1000 mm Tol. in 1/1000 mm	
87042426 hm			Massstab: Echelle: Scale:		
94017213 kg			Datum: Date:	24. 2. 87	Kontrolliert: Contrôlé: <i>hm</i>
97023830 hm					Checked:

Aiguillages
Zeigerwerkhöhen
Hand fitting heights

Cal. 955.122/132/422
956.122

Ajustement aiguille des heures
Stundenzeigerpassung
Hour hand fitting

Ajustement aiguille des minutes
Minutenzeigerpassung
Minute hand fitting

Ajustement aiguille des secondes
Sekundenzeigerpassung
Second hand fitting

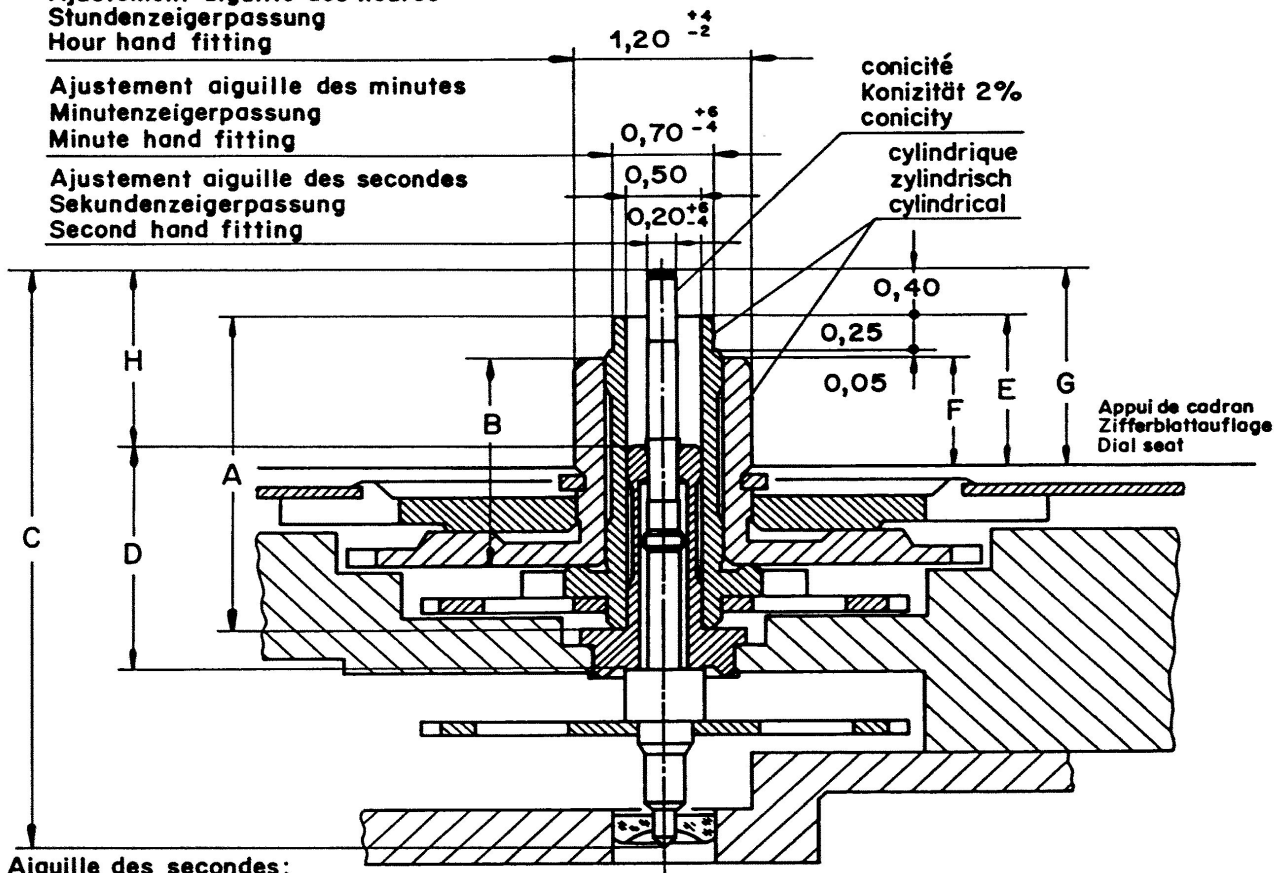

Aiguille des secondes:
Sekundenzeiger
Second hand
balourd
Unwucht $\leq 0,04 \mu\text{Nm}$ (0,004 pmm)
unbalance
masse
Masse $\leq 10 \text{ mg}$
mass

Aiguille des minutes:
Minutenzeiger
Minute hand
balourd
Unwucht $\leq 3,0 \mu\text{Nm}$ (0,3 pmm)
unbalance

Aiguillage Zeigerwerk- höhe Hand fitting height	Longueur/Länge/Length				Dépassement Höhe über Zifferblattauflage Height over dial seat			H
	A	B	C	D	E	F	G	
	Chaussée Minutenrohr Cannon-pinion	Roue des heures Stundenrad Hour wheel	Pignon des secondes Sekundentrieb Second wheel pinion	Tube de centre Zentrumrohr Centre tube	Chaussée Minutenrohr Cannon-pinion	Roue des heures Stundenrad Hour wheel	Pignon des secondes Sekundentrieb Second wheel pinion	
3 normal	2,38	1,56	4,38	1,70	1,10	0,80	1,50	1,35

Aenderungen: 10 1.83.hm, 18.6.84.hm λ ,
27.6.84.hm λ , 4.3.86.hm λ , 86081947hm λ ,
87042426hm, 94017213 kg



ETA SA Fabriques d'Ebauches
CH-2540 Grenchen

Kontr.-Richtl.

Masse in mm. Tol. in 1/1000mm

Datum: 6.12.82



Maßstab:

Gezeichnet: *je*

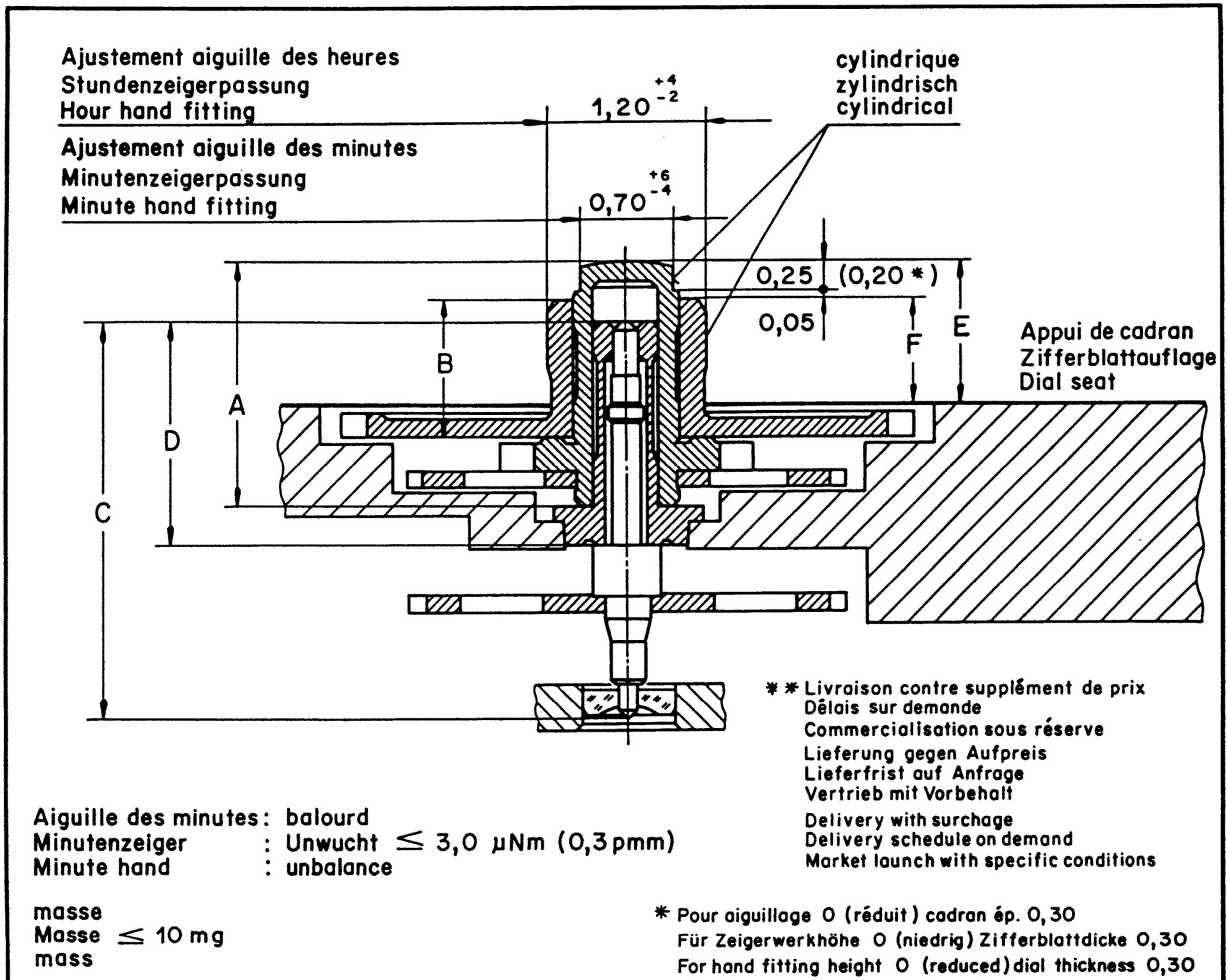
Kontrolliert: *P*



Aiguillage Zeigerwerk- höhe Hand fitting height	Longueur/Länge/Length				Dépassement Höhe über Zifferblattauflage Height over dial seat	
	A	B	C	D	E	F
	Chaussée Minutenrohr Cannon - pinion	Roue des heures Stundenrad Hour wheel	Pig. des secondes Sekundentrieb Sec. wheel pinion	Tube de centre Zentrumrohr Centre tube	Chaussée Minutenrohr Cannon - pinion	Roue des heures Stundenrad Hour wheel
réduit * niedrig reduced	1,66	0,89	3,03	1,70	0,90	0,65
1 normal	1,88	1,06	3,03	1,70	1,10	0,80
3 **	2,38	1,56	3,03	1,70	1,60	1,30
4 **	2,63	1,81	3,03	1,70	1,85	1,55
6 **	3,13	2,31	3,03	1,70	2,35	2,05

Aiguillages Zeigerwerkhöhen Hand fitting heights			Cal. 955.432 956.032/042			
Änderungen: Modifications:			 ETA SA Fabriques d'Ebauches CH-2540 Grenchen	Masse in mm Dim. en mm Dim. in mm	Tol. in 1/1000 mm Tol. en 1/1000 mm Tol. in 1/1000 mm	
970910844 hm				Massestab: Echelle: Scale:	20 : 1	
990312658 hm				Datum: Date:	3. 3. 87	Kontrolliert: Contrôlé: Checked: 

Contrôles électriques – Elektrische Kontrollen – Electrical tests

955.402
955.412
955.422
955.432

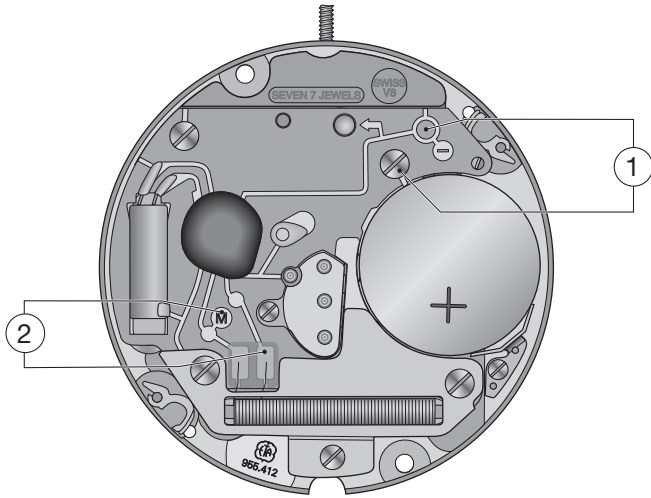

955.102
955.112
955.122
955.132

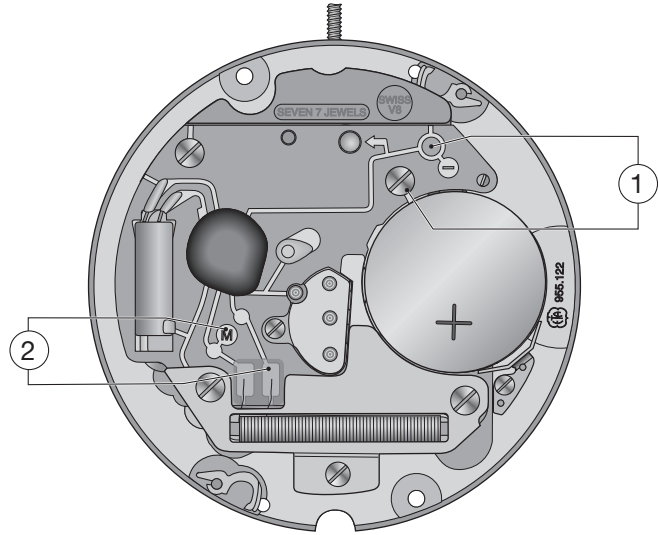

955.402
955.412
955.422

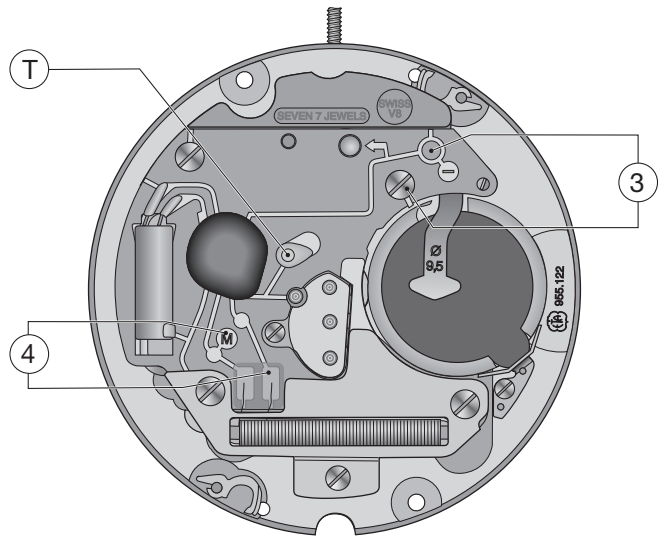
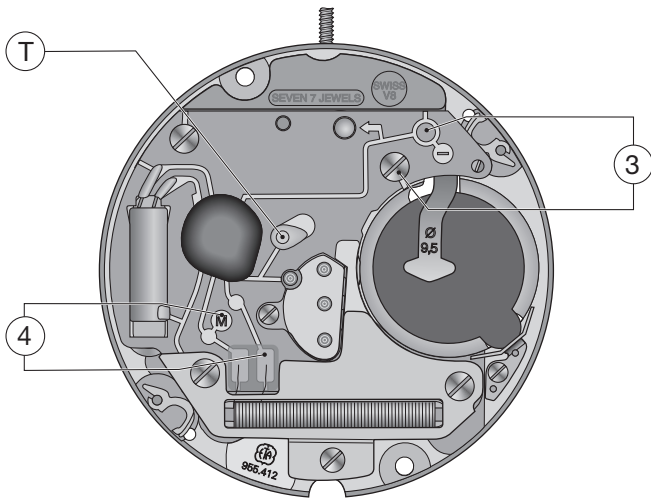

955.432

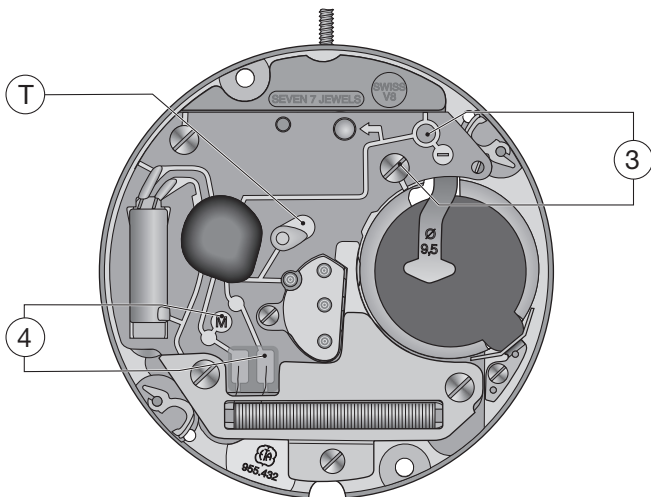

Contrôles électriques – Elektrische Kontrollen – Electrical tests

Position Messpunkt Position	Echelle de mesure Einstellung Messgerät Setting of apparatus	Mesure Messung Measurement	Contrôle Kontrolle Test	Remarques Bemerkungen Remarks	
1	2 V (Ri ≥ 10 kΩ / V)	1,55 V	Tension de la pile Spannung der Batterie Battery voltage	Mesure avec pile. Messung mit Batterie. Measurement with battery.	
2	1 V (Ri ≥ 10 kΩ / V)	L'aiguille du multimètre oscille en sens + et –. Zeiger im Messgerät pulsiert im + und – Sinn. Hand of the measuring apparatus oscillates in + and – direction.	Impulsions à la sortie du circuit intégré: Ausgangsimpulse am integrierten Schaltkreis: Impulses at output of integrated circuit: 955.432 955.102/112/122/132 955.402/412/422 12 / min. 1 / s	Mesure avec une pile contrôlée. Messung mit kontrollierter Batterie. Measurement with controlled battery.	
3	2 V	≤ 1,30 V 955.432 955.102/112/122/132 955.402/412/422 Mettre en contact le point ⊕ et la piste ⊖. Commande du moteur avec 16 pas/s. ⊕ Punkt mit der ⊖ Spur verbinden. Motorantrieb mit 16 Schritten/S. Connect ⊕ point with the ⊖ conductor. Motor driven with 16 steps/s.	≤ 1,30 V 955.102/112/122/132 955.402/412/422 Mettre en contact le point ⊕ et la piste ⊖. Commande du moteur avec 8 pas/s à 1,55 V et 32 pas/s avec tension ≤ 1,30 V (E.O.L). ⊕ Punkt mit der ⊖ Spur verbinden. Motorantrieb mit 8 Schritten/S bei 1,55 V und 32 Schritten/S mit Spannung ≤ 1,30 V (E.O.L). Connect ⊕ point with the ⊖ conductor. Motor driven with 8 steps/s at 1.55 V and 32 steps/s with voltage ≤ 1.30 V (E.O.L).	Limite inférieure de la tension de fonctionnement Untere Funktionsspannungsgrenze Lower working-voltage limit	Mesure sans pile, alimentation extérieure variable, en descendant de 1,55 V à l'arrêt du mouvement. Messung ohne Batterie mit variabler Speisung von aussen, Spannung von 1,55 V reduzieren bis zum Stillstand des Werkes. Measurement without battery, with variable external power supply, starting with 1.55 V, lower tension until movement stops.
	10 μA	955.432 ≤ 0,70 μA	955.102/112/122/132 955.402/412/422 ≤ 1,30 μA	Consommation du mouvement Stromaufnahme Uhrwerk Consumption of movement	Mesure sans pile, avec alimentation extérieure 1,55 V. Messung ohne Batterie, mit Speisegerät 1,55 V. Measurement without battery, with external power supply 1.55 V.
			Saut de 4 pas toutes les 4 sec. lorsque la tension d'alimentation < 1,30 V. 4-Schritte-Sprung alle 4 Sek. wenn Speisepannung < 1,30 V. 4 steps jump every 4 sec., when feed voltage < 1.30 V.	E.O.L. Consommation supérieure à la valeur normale. E.O.L. Stromaufnahme über Normalwert. E.O.L. Consumption higher than in normal operation.	Mesure sans pile, avec tension d'alimentation < 1,30 V, Fonction E.O.L après ~ 2 min. Messung ohne Batterie, mit Speisespannung < 1,30 V, E.O.L-Funktion nach ca. 2 Min. Measurement without battery, with feed voltage < 1.30 V, E.O.L function after about 2 min.
		≤ 0,5 μA	Fonctionnement de l'interrupteur en pos. 3 de la tige de mise à l'heure. Funktion des Stopphebels, Pos. 3 der Zeigerstellwelle. Function of stop lever, pos. 3 of handsetting stem.	Mesure sans pile, avec alimentation extérieure 1,55 V. Messung ohne Batterie, mit Speisegerät 1,55 V. Measurement without battery, with external power supply 1.55 V.	
4	● 10 kΩ 200 μA	1,3 – 1,8 kΩ 110 – 155 μA	Continuité du bobinage Zustand der Spule Condition of coil		

Ohmmètres avec tension de mesure supérieure à 0,40 V inappropriés, tension recommandée 0,20 V.
● Ohmmeter mit Prüfspannung über 0,40 V ungeeignet, empfohlene Spannung 0,20 V.
Ohmmeter with a test voltage higher than 0.40 V unsuitable, recommended voltage 0.20 V.

Température ambiante 20°C.
Raumtemperatur 20°C.
Ambient temperature 20°C.

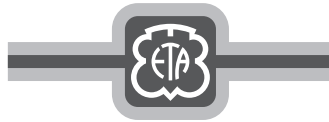

ETA SA Manufacture Horlogère Suisse
Customer Service

Dimensions des vis

7³/₄ "" 956.032,042,102,112,113
10¹/₂ "" 955.412,413,422,423,432

8³/₄ "" 956.412
11¹/₂ "" 955.112,122,132

	<p>tête non coupée N° 1859.447.80 509.555 tête coupée N° 1859.447.00 509.554 0,018 Nm (180 pcm) Vis de fixation (2) Seulement Cal. 955 et 8³/₄ Cal. 956.412</p>		<p>tête non coupée N° 1859.448.80 509.557 tête coupée N° 1859.448.00 509.556 0,01 Nm (100 pcm) Vis de fixation (2) Seulement Cal. 956.032,042 102,112,113</p>
	<p>N° 1859.673.00 0,018 Nm (180 pcm) Vis de fixation (2) Seulement sur demande à la place 1859.447.40</p>		<p>N° 1803.449.00 500.556 0,007 Nm (70 pcm) Vis de pont rouge</p>
	<p>N° 1813.181.02 500.264 0,007 Nm (70 pcm) Vis de pont minuterie Vis de pont sautoir (n'est pas utilisée pour Cal. 955.132,432)</p>		<p>N° 1813.181.02 500.264 0,007 Nm (70 pcm) Vis ressort sautoir des jours Seulement Cal. 955.122,422,423</p>
	<p>N° 1852.238.01 500.26X 0,006 Nm (60 pcm) Seulement Cal. 955.122,422,423</p>		<p>N° 1803.530.00 500.955 0,007 Nm (70 pcm) Vis module électronique longue Cal. 955 (3) Cal. 956 (2)</p>
	<p>N° 1803.529.00 500.555 0,007 Nm (70 pcm) Vis fixation écran magnétique Vis fixation bride de masse</p>		<p>N° 1803.832.00 500.832 0,007 Nm (70 pcm) Vis module électronique courte</p>

Nm (Newton m) : Minimum du moment de force pour dévisser la vis.
pcm (pond cm) : Minimales Kraftmoment zum Lösen der Schraube.

September 1992

Cette page est laissée blanche intentionnellement.

Diese Seite wird absichtlich weiss gelassen.

This page was left blank intentionally.



ETA SA Manufacture Horlogère Suisse
Customer Service
 Bahnhofstrasse 9
 P.O. Box 359
 CH-2540 Grenchen
 Phone +41 (0)32 655 27 77
 Fax +41 (0)32 655 84 30
 e-mail: etacs@eta.ch
 www.eta.ch

03	19.12.05	Correction dans l'ordre d'assemblage Korrektur in Montagerihenfolge Correction in order assembly	7
		Orientation isolateur 4046 dans dessin contrôles électriques Richtung Isolation 4046 in Zeichnung Elektrische Kontrollen Orientation insulator 4046 in drawing Electrical test	12
Version	Date Datum Date	Modification Aenderung Modification	Page Seite Page